



WARREN MORRISON UK LTD



PNEUMATIC ACTUATORS PD & PS SERIES

Warren-Morrison Valves

Established in 1949 in the United Kingdom, Warren-Morrison UK Ltd. has been manufacturing its own unique range of industrial valves and actuators for over 65 years. Benefiting from our own internal rubber mould department, machine shop and development and test facilities, we maintain total control over production and quality through continuous 'in process inspection'. Our dedication towards future development has continued to ensure our market position as a select industrial valve and accessories manufacturer and supplier.

Warren-Morrison Pneumatic Actuator

The Warren Morrison P Series Pneumatic Actuator is a rack and pinion quarter turn actuator. It comes in both single acting with fail safe position and in double acting configuration. Designed to cover a wide span of torques with high torque values. As well as being rugged and reliable for extended use, the actuator body comes in anodized aluminum material while the ends caps come in epoxy coated aluminum material. The bottom mounting is designed to suit ISO 5211 and DIN 3337 while the top mounting is designed to suit VDI/VDE 3845 NAMUR.

Pneumatic Actuator Features:

- Rigid anodized body material with epoxy coated end caps.
- Clear indicator with gradual scale to show the position of the valve connected to the actuator.
- Compatibility to international standards for the top and bottom flange drilling.
- Various designs and material compatibility to suit different temperature ranges.
- Various types of coating to suit most environment.
- Different adaptors can be provided to suit numerous types of valves.
- Tested for more than two million cycles.
- Direct fitting to WM Manual override.
- Option for Stainless steel body up to the size PD/PS210.

Actuator Dimension and Weight

PD052/PS052 to PD350/PS350

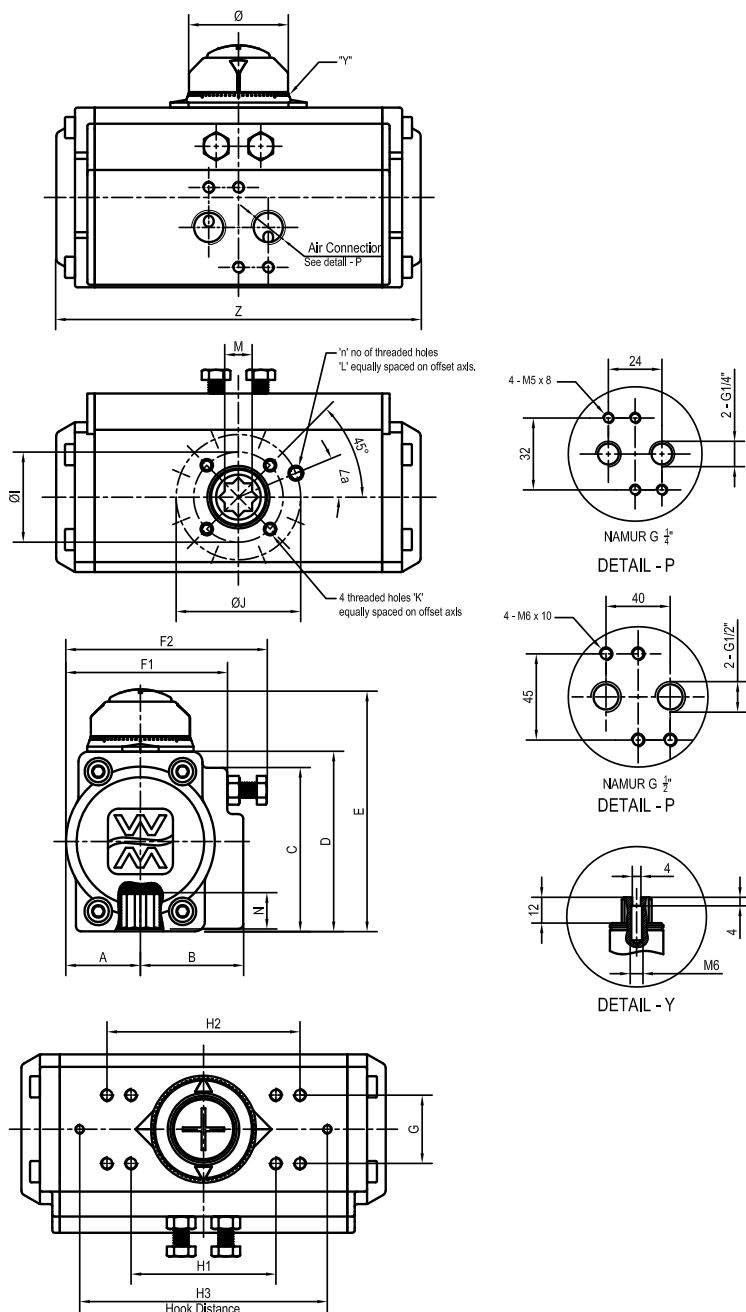

PD400/PS400

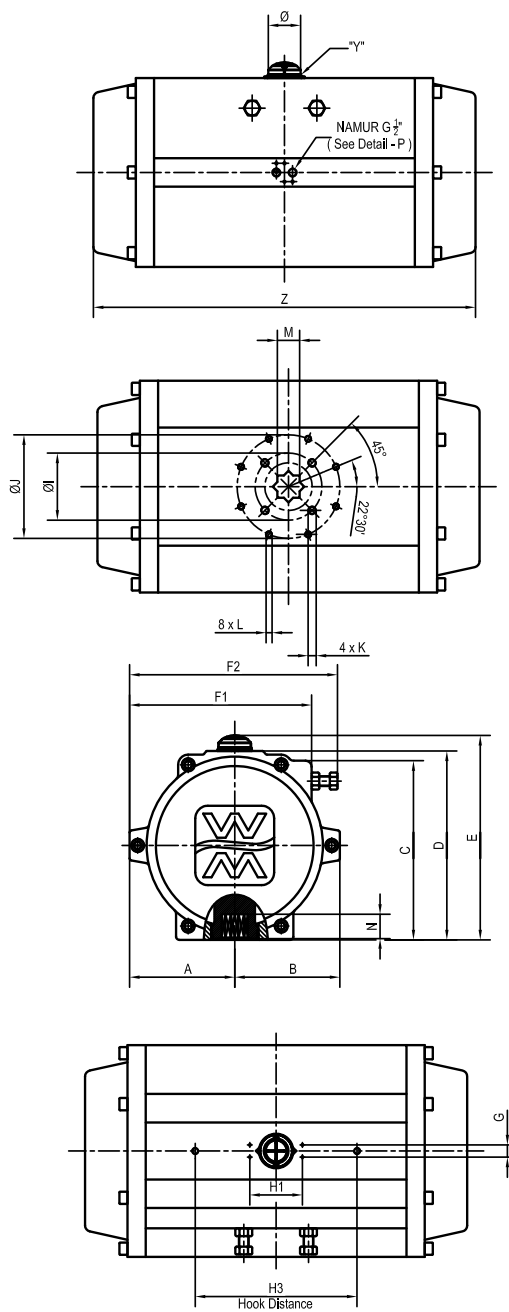

PD/PS Dimensions and Weight

Model	A	B	C	D	E	F1	F2	G	H1	H2	H3	I	J	K	L	n	∠a	M	N	Z	Ø	Air Connection	Weight DA (Kg)	Weight SA (Kg)
PD052 / PS052	30.5	41.5	65.5	72	96	65.5	80.5	30	80			Ø36	Ø50	M5x8	M6x10	4	45°	11	14	150	Ø40	G1/4"	1.35	1.53
PD063 / PS063	36	47	81	88	112	72.5	88.2	30	80			Ø50	Ø70	M6x10	M8x13	4	45°	14	19	172	Ø40	G1/4"	2.14	2.33
PD075 / PS075	42.5	53	94	100	124	81.5	94.4	30	80			Ø50	Ø70	M6x10	M8x13	4	45°	14	19	188	Ø40	G1/4"	2.58	2.86
PD083 / PS083	46	57	98.5	109	133.5	92	116.7	30	80			Ø50	Ø70	M6x10	M8x13	4	45°	17	23	221	Ø40	G1/4"	3.38	3.78
PD092 / PS092	50	58.5	111	117	141	98	124	30	80			Ø50	Ø70	M6x10	M8x13	4	45°	17	23	268	Ø40	G1/4"	4.52	5.28
PD105 / PS105	58	64	123.5	134.5	158	110	131	30	80			Ø70	Ø102	M8x13	M10x16	4	45°	22	31	279	Ø40	G1/4"	5.90	6.74
PD125 / PS125	68	75	146	156.5	192	128	149	30	80	130		Ø70	Ø102	M8x13	M10x16	4	45°	22	31	322	Ø55	G1/4"	9.20	10.54
PD140 / PS140	76	77	161.5	173.5	209	138.5	163.5	30	80	130		Ø102	Ø125	M10x16	M12x20	4	45°	27	35	406	Ø55	G1/4"	12.00	14.52
PD160 / PS160	87.5	87.5	185.5	198.5	234.5	159	184.5	30	80	130		Ø102	Ø125	M10x16	M12x20	4	45°	27	35	475	Ø55	G1/4"	20.25	24.15
PD190 / PS190	103.5	103.5	216.5	231	269	189.5	223.5	30	130		312	Ø140		M16x25		4	45°	36	40	544	Ø80	G1/4"	31.35	36.81
PD210 / PS210	113.5	113.5	236	256	294	211	245	30	130		318	Ø140		M16x25		4	45°	36	40	562	Ø80	G1/4"	45.70	55.24
PD240 / PS240	130.5	130.5	266.5	292	330	246.5	288	30	130		344	Ø165		M20x25		4	45°	46	58	642	Ø80	G1/4"	54.50	67.82
PD270 / PS270	147.5	147.5	302	331	368	274	315.5	30	130		434	Ø165		M20x25		4	45°	46	58	740	Ø80	G1/2"	79.00	102.28
PD300 / PS300	162	173	329	352	390	312	361	30	130		350	Ø165		M20x25		4	45°	46	55	774	Ø80	G1/2"	99.00	126.60
PD350 / PS350	190	195	382	408	446	362	426	30	130		400	Ø165	Ø254	M20x25	M16x25	8	22°30'	46	55	912	Ø80	G1/2"	156.00	205.20
PD400 / PS400	260	260	440	464	502	450	514	30	130		400	Ø165	Ø254	M20x25	M16x25			55	60	945	Ø80	G1/2"	212.00	263.60

Single Acting Output Torque

Single Acting PS Series Output Torque (N·m)

		Air Supply Pressure (Bar)																Springs Output	
Model Number	Spring Qty	2.5		3		4		5		5.5		6		7		8		Start	End
		Start	End	Start	End	Start	End	Start	End	Start	End	Start	End	Start	End	Start	End		
PS052	5	5	3	7	5	10	9	14	12	16	14	18	16	22	20	25	23	5	3
	6	4	2	6	4	10	7	13	11	15	13	17	15	21	19	25	22	6	4
	7	3	1	5	3	9	6	13	10	14	12	16	14	20	17	24	21	8	5
	8	0	0	4	1	8	5	12	9	14	11	16	13	19	16	23	20	9	6
	9	0	0	4	0	7	4	11	8	13	10	15	11	18	15	22	19	10	7
	10	0	0	0	0	7	3	10	7	12	8	14	10	18	14	21	18	11	7
	11	0	0	0	0	6	2	9	5	11	7	13	9	17	13	21	17	12	8
	12	0	0	0	0	0	0	9	4	11	6	12	8	16	12	20	15	13	9
PS063	5	10	6	13	9	19	16	26	22	29	26	32	29	39	36	46	42	9	6
	6	8	4	12	7	18	14	25	21	28	24	31	27	38	34	44	40	11	7
	7	7	2	10	5	17	12	23	19	27	22	30	25	36	32	43	38	13	8
	8	0	0	9	4	16	10	22	17	25	20	29	23	35	30	42	36	15	10
	9	0	0	8	2	14	8	21	15	24	18	27	21	34	28	40	34	17	11
	10	0	0	0	0	13	6	20	13	23	16	26	19	33	26	39	32	19	12
	11	0	0	0	0	12	4	18	11	22	14	25	17	31	24	38	30	21	13
	12	0	0	0	0	0	0	17	9	20	12	24	15	30	22	37	28	23	15
PS075	5	13	9	18	14	27	23	36	32	41	37	45	42	55	51	64	60	13	9
	6	11	7	16	11	25	20	34	30	39	34	43	39	53	48	62	58	16	11
	7	9	4	14	8	23	18	32	27	37	32	42	36	51	46	60	55	18	13
	8	0	0	12	6	21	15	30	24	35	29	40	34	49	43	58	52	21	15
	9	0	0	10	3	19	12	28	22	33	26	38	31	47	40	56	49	24	17
	10	0	0	0	0	17	10	26	19	31	24	36	28	45	37	54	47	26	19
	11	0	0	0	0	15	7	25	16	29	21	34	26	43	35	52	44	29	21
	12	0	0	0	0	0	0	23	14	27	18	32	23	41	32	50	41	32	23
PS083	5	20	14	28	21	42	35	56	49	63	56	70	63	84	77	99	92	21	14
	6	18	9	25	16	39	31	53	45	60	52	67	59	81	73	96	87	25	17
	7	15	5	22	12	36	26	50	40	57	48	64	55	79	69	93	83	30	20
	8	0	0	19	8	33	22	47	36	54	43	61	50	76	65	90	79	34	23
	9	0	0	16	3	30	18	44	32	51	39	59	46	73	60	87	74	38	26
	10	0	0	0	0	27	13	41	28	48	35	56	42	70	56	84	70	42	29
	11	0	0	0	0	24	9	38	23	46	30	53	37	67	52	81	66	47	31
	12	0	0	0	0	0	0	36	19	43	26	50	33	64	47	78	62	51	34
PS092	5	30	20	41	30	62	51	83	72	93	83	104	93	125	114	145	135	31	21
	6	26	14	37	24	57	45	78	66	89	76	99	87	120	108	141	129	38	25
	7	22	7	32	18	53	39	74	60	85	70	95	80	116	101	137	122	44	30
	8	0	0	28	11	49	32	70	53	80	64	91	74	112	95	133	116	51	34
	9	0	0	24	5	45	26	65	47	76	57	86	68	107	89	128	110	57	38
	10	0	0	0	0	40	19	61	40	72	51	82	61	103	82	124	103	63	42
	11	0	0	0	0	36	13	57	34	67	44	78	55	99	76	120	97	70	47
	12	0	0	0	0	0	0	53	28	63	38	74	49	94	69	115	90	76	51
PS105	5	46	29	61	45	92	75	122	105	137	120	152	135	182	166	213	196	45	29
	6	40	20	55	35	86	66	116	96	131	111	146	126	177	157	207	187	54	34
	7	34	11	50	26	80	57	110	87	125	102	140	117	171	147	201	178	64	40
	8	0	0	44	17	74	47	104	78	120	93	135	108	165	138	195	169	73	46
	9	0	0	38	8	68	38	99	68	114	84	129	99	159	129	189	159	82	52
	10	0	0	0	0	62	29	93	59	108	74	123	90	153	120	184	150	91	58
	11	0	0	0	0	57	20	87	50	102	65	117	80	147	111	178	141	100	64
	12	0	0	0	0	0	0	81	41	96	56	111	71	142	102	172	132	109	69
PS125	5	69	44	92	67	139	114	182	158	206	181	229	204	275	250	321	297	72	48
	6	57	28	80	51	127	97	173	143	196	166	219	189	265	236	312	282	87	57
	7	48	13	71	36	117	82	163	129	186	152	209	175	256	221	302	267	102	67
	8	0	0	61	21	107	68	153	114	177	137	200	160	246	206	292	253	116	77
	9	0	0	51	7	98	53	144	99	167	122	190	146	236	192	283	238	131	86
	10	0	0	0	0	88	39	134	85	157	108	180	131	227	177	273	224	145	96
	11	0	0	0	0	78	24	124	70	148	93	171	116	217	163	263	209	160	106
	12	0	0	0	0	0	0	115	56	138	79	161	102	207	148	254	194	175	115
PS140	5	118	78	158	117	237	196	316	275	355	315	395	355	474	434	553	513	119	79
	6	102	54	142	93	221	172	300	251	340	291	379	331	458	410	537	489	143	94
	7	87	30	126	69	205	148	284	228	324	267	363	307	443	386	522	465	167	110
	8	0	0	110	45	189	125	268	204	308	243	348	283	427	362	506	441	191	126
	9	0	0	94	21	174	101	253	180	292	219	332	259	411	338	490	417	215	142
	10	0	0	0	0	158	77	237	156	276	195	316	235	395	314	474	393	239	158
	11	0	0	0	0	142	53	221	132	261	171	300	211	379	290	458	369	263	174
	12	0	0	0	0	0	0	205	108	245	147	284	187	363	266	443	345	287	189

Single Acting Output Torque

Single Acting PS Series Output Torque (N·m)

		Air Supply Pressure (Bar)																Springs Output	
Model Number	Spring Qty	2.5		3		4		5		5.5		6		7		8		Start	End
		Start	End	Start	End	Start	End	Start	End	Start	End	Start	End	Start	End	Start	End		
PS160	5	177	112	239	173	361	296	483	418	545	479	606	540	728	663	851	785	193	128
	6	152	73	213	134	335	257	458	379	519	440	580	502	703	624	825	747	232	154
	7	126	34	187	96	310	218	432	341	493	402	0	463	677	585	799	708	271	179
	8	0	0	162	57	284	179	406	302	468	363	529	424	651	547	774	669	309	205
	9	0	0	136	18	258	141	381	263	442	324	503	385	626	508	748	630	348	231
	10	0	0	0	0	233	102	355	224	416	285	478	347	600	469	722	592	387	256
	11	0	0	0	0	207	63	329	186	391	247	452	308	574	430	697	553	426	282
12	0	0	0	0	0	0	304	147	365	208	426	269	549	392	671	514	464	308	
PS190	5	306	203	404	301	601	497	797	694	895	792	993	890	1190	1086	1386	1283	287	183
	6	270	145	368	244	564	440	760	636	858	734	957	833	1153	1029	1349	1225	344	220
	7	233	88	331	186	527	382	724	579	822	677	920	775	1116	971	1312	1168	402	257
	8	0	0	294	129	490	325	687	521	785	619	883	718	1079	914	1276	1110	459	294
	9	0	0	257	71	454	267	650	464	748	562	846	660	1043	856	1239	1053	517	331
	10	0	0	0	0	417	210	613	406	711	504	809	603	1006	799	1202	995	574	367
	11	0	0	0	0	380	152	576	349	674	447	773	545	969	741	1165	938	632	404
12	0	0	0	0	0	0	540	291	638	389	736	488	932	684	1128	880	689	441	
PS210	5	359	255	481	378	726	622	971	867	1093	990	1215	1112	1460	1357	1705	1602	356	253
	6	308	184	430	306	675	551	920	796	1042	918	1165	1041	1410	1286	1655	1530	427	303
	7	257	113	380	235	625	480	869	725	992	847	1114	970	1359	1214	1604	1459	498	354
	8	0	0	329	164	574	409	819	653	941	776	1064	898	1308	1143	1553	1388	570	404
	9	0	0	279	93	523	337	768	582	891	705	1013	827	1258	1072	1503	1317	641	455
	10	0	0	0	0	473	266	718	511	840	633	962	756	1207	1001	1452	1245	712	506
	11	0	0	0	0	422	195	667	440	789	562	912	685	1157	929	1401	1174	783	556
12	0	0	0	0	0	0	616	368	739	491	861	613	1106	858	1351	1103	855	607	
PS240	5	507	358	685	535	1039	889	1393	1243	1570	1421	1747	1598	2102	1952	2456	2306	527	377
	6	432	252	609	430	963	784	1317	1138	1495	1315	1672	1492	2026	1847	2380	2201	632	453
	7	356	147	533	324	888	678	1242	1033	1419	1210	1596	1387	1950	1741	2305	2095	738	528
	8	0	0	458	219	812	573	1166	927	1344	1104	1521	1281	1875	1636	2229	1990	843	604
	9	0	0	382	113	737	467	1091	822	1268	999	1445	1176	1799	1530	2154	1884	948	679
	10	0	0	0	0	661	362	1015	716	1192	893	1370	1071	1724	1425	2078	1779	1054	755
	11	0	0	0	0	586	257	940	611	1117	788	1294	965	1648	1319	2003	1674	1159	830
12	0	0	0	0	0	0	864	505	1041	683	1219	860	1573	1214	1927	1568	1265	906	
PS270	5	790	553	1059	822	1597	1360	2135	1898	2404	2167	2673	2436	3211	2974	3749	3512	791	554
	6	679	395	948	664	1486	1202	2024	1740	2293	2009	2562	2278	3100	2816	3638	3354	949	665
	7	568	237	837	506	1375	1044	1913	1582	2182	1851	2451	2120	2989	2658	3527	3196	1107	776
	8	0	0	727	348	1265	886	1803	1424	2072	1693	2341	1962	2879	2500	3417	3038	1265	886
	9	0	0	616	189	1154	727	1692	1265	1961	1534	2230	1803	2768	2341	3306	2879	1424	997
	10	0	0	0	0	1043	569	1581	1107	1850	1376	2119	1645	2657	2183	3195	2721	1582	1108
	11	0	0	0	0	932	411	1470	949	1739	1218	2008	1487	2546	2025	3084	2563	1740	1219
12	0	0	0	0	0	0	1359	791	1628	1060	1897	1329	2435	1867	2973	2405	1898	1330	
PS300	5	1053	725	1408	1080	2119	1791	2830	2502	3185	2857	3541	3213	4252	3924	4963	4635	1051	723
	6	908	514	1263	870	1974	1581	2685	2292	3041	2647	3396	3002	4107	3713	4818	4424	1262	868
	7	0	0	1119	659	1829	1370	2540	2081	2896	2437	3251	2792	3962	3503	4673	4214	1472	1013
	8	0	0	974	449	1685	1160	2396	1871	2751	2226	3106	2582	3817	3293	4528	4003	1682	1158
	9	0	0	0	0	1540	950	2251	1660	2606	2016	2962	2371	3673	3082	4383	3793	1893	1303
	10	0	0	0	0	1395	739	2106	1450	2461	1806	2817	2161	3528	2872	4239	3583	2103	1447
	11	0	0	0	0	1250	529	1961	1240	2317	1595	2672	1951	3383	2661	4094	3372	2314	1592
12	0	0	0	0	0	0	1816	1029	2172	1385	2527	1740	3238	2451	3949	3162	2524	1737	
PS350	5	1521	1007	2053	1539	3118	2604	4182	3668	4714	4200	5246	4732	6311	5797	7375	6861	1653	1139
	6	1293	676	1825	1209	2890	2273	3954	3337	4486	3869	5018	4402	6083	5466	7147	6530	1983	1367
	7	0	0	1598	878	2662	1942	3726	3007	4258	3539	4791	4071	5855	5135	6919	6200	2314	1594
	8	0	0	1370	547	2434	1612	3498	2676	4031	3208	4563	3740	5627	4805	6691	5869	2645	1822
	9	0	0	0	0	2206	1281	3270	2345	3803	2878	4335	3410	5399	4474	6463	5538	2975	2050
	10	0	0	0	0	1978	950	3043	2015	3575	2547	4107	3079	5171	4143	6236	5208	3306	2278
	11	0	0	0	0	0	0	2815	1684	3347	2216	3879	2748	4943	3813	6008	4877	3637	2506
12	0	0	0	0	0	0	2587	1353	3119	1886	3651	2418	4716	3482	5780	4546	3967	2734	
PS400	7	2014	1148	2772	1906	4289	3423	5805	4940	6564	5698	7322	6456	8839	7973	10355	9489	2642	1776
	8	1760	771	2519	1529	4035	3045	5552	4562	6310	5320	7068	6079	8585	7595	10101	9112	3020	2030
	9	0	0	2265	1151	3781	2668	5298	4184	6056	4943	6814	5701	8331	7218	9847	8734	3397	2284
	10	0	0	2011	774	3528	2290	5044	3807	5802	4565	6561	5324	8077	6840	9594	8357	3775	2538
	11	0	0	0	0	3274	1913	4790	3429	5548	4188	6307	4946	7823	6463	9340	7979	4152	2791
12	0	0	0	0	3020	1535	4536	3052	5295	3810	6053	4568	7569	6085	9086	7602	4530	3045	

Double Acting PD Series Output Torque (N·M)

Model Number	Air Supply Pressure (Bar)									
	2	2.5	3	4	4.5	5	5.5	6	7	8
PD052	7	9	11	15	17	19	20	22	26	30
PD063	14	17	20	27	31	34	38	41	48	55
PD075	19	23	28	38	42	47	52	57	66	76
PD083	29	37	44	59	66	74	81	89	104	118
PD092	42	53	64	85	96	107	117	128	150	171
PD105	62	78	94	125	141	156	172	188	219	250
PD125	95	118	142	190	214	238	262	285	333	380
PD140	162	203	243	324	365	405	446	487	568	649
PD160	252	315	379	505	568	631	694	758	884	1010
PD190	404	505	606	808	910	1010	1111	1213	1415	1616
PD210	505	631	758	1010	1137	1263	1389	1516	1768	2021
PD240	730	913	1096	1462	1644	1827	2010	2192	2558	2924
PD270	1239	1549	1860	2479	2790	3099	3409	3720	4340	4959
PD300	1468	1835	2202	2936	3303	3670	4037	4404	5138	5872
PD350	2198	2747	3297	4396	4945	5495	6044	6594	7693	8792
PD400	3131	3914	4697	6263	7046	7829	8612	9395	10961	12527

Actuator Speed (Seconds)

Double Acting Model Number	52	63	75	83	92	105	125	140	160	190	210	240	270	300	350	400
Opening time (Sec)	0.2	0.3	0.3	0.4	0.6	0.8	0.9	1.4	1.7	2.4	2.7	3.5	4.0	6.0	8.5	10.0
Closing time (Sec)	0.2	0.3	0.4	0.5	0.6	0.8	1.1	1.4	1.8	2.5	3.2	4.0	4.5	6.5	9.0	11.0

The stroke time indicated is measured with the air pressure at 5.5 bar.

Actuator Volume (Liters)

Model Number	PD052 PS052	PD063 PS063	PD075 PS075	PD083 PS083	PD092 PS092	PD105 PS105	PD125 PS125	PD140 PS140	PD160 PS160	PD190 PS190	PD210 PS210	PD240 PS240	PD270 PS270	PD300 PS300	PD350 PS350	PD400 PS400
Opening volume (L)	0.09	0.14	0.22	0.34	0.50	0.77	1.25	2.16	3.39	5.59	6.64	9.68	14.93	21.50	31.20	47.90
Closing volume (L)	0.19	0.26	0.38	0.53	0.93	1.19	1.72	3.20	4.83	7.94	10.53	16.29	24.62	30.00	43.70	67.10

Spring Mounting

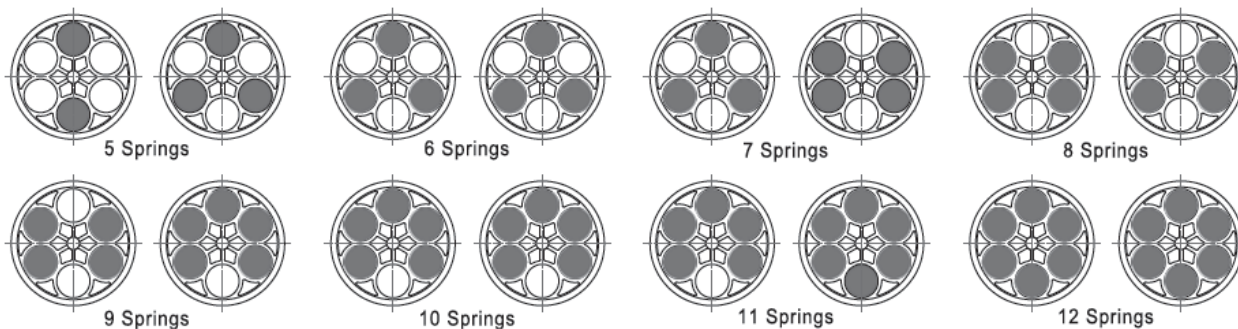

Parts and Model Numbering System

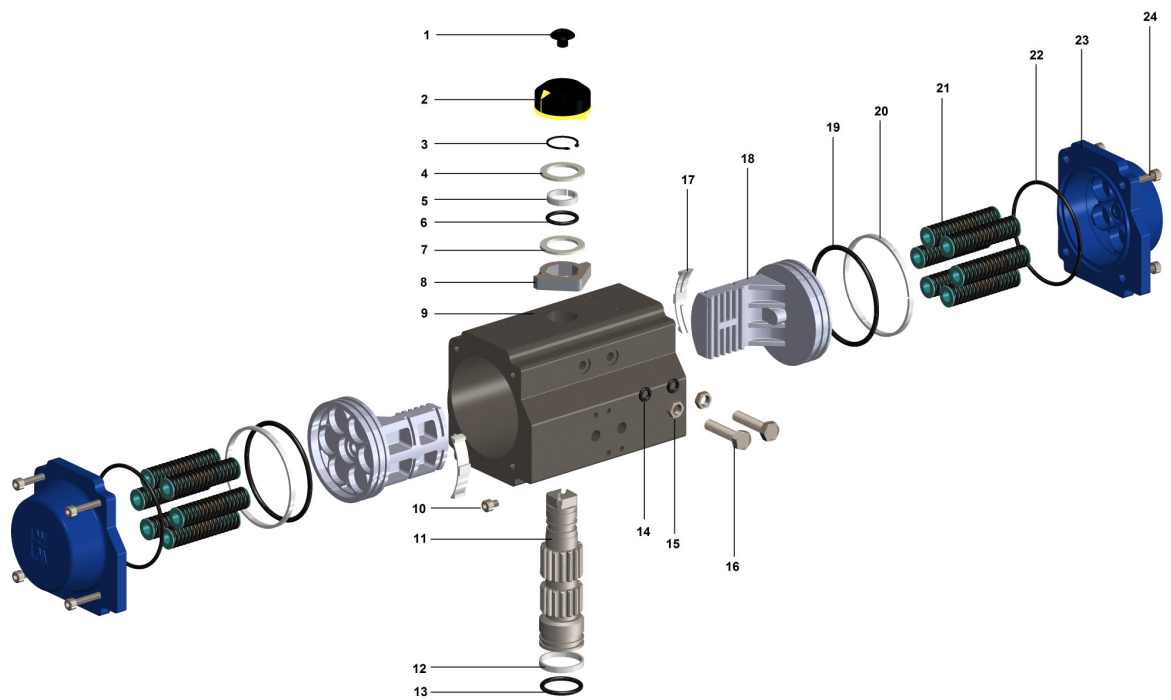

Item	Name	Qty
1	Indictator screw	1
2	Indictator	1
3	Spring clip	1
4	Thrust washer	1
5	Outside washer	1
6	O-ring (pinion top)	1
7	Inside Washer	1
8	Cam	1
9	Body	1
10	Plug	2
11	Pinion	1
12	Bearing (pinion bottom)	1

Item	Name	Qty
13	O-ring (pinion bottom)	1
14	O-ring (adjust screw)	2
15	Nut (adjust screw)	2
16	Adjust screw	2
17	Guide (piston)	2
18	Piston	2
19	O-Ring (piston)	2
20	Bearing (piston)	2
21	Spring	0-12
22	O-ring (end cap)	2
23	End cap	2
24	Cap screw	8

Model Numbering System for WM Pneumatic Actuator

Series		Action		Cylinder Size		No of Springs		Fail Position		-	Specials	
P	Pneumatic Actuator	D	Double Acting	052	52	00	0	L	Last		S	Standard Temperature -20°C to +80°C
		S	Single Acting	063	63	05	5	C	Close		L	Low Temperature -40°C to +80°C
				075	75	06	6	O	Open		H	Hight Temperature -15°C to +150°C
				083	83	07	7				E	Epoxy Coated
				092	92	08	8				P	PTFE Coated
				105	105	09	9				X	Special
				125	125	10	10					
				140	140	11	11					
				160	160	12	12					
				190	190							
				210	210							
				240	240							
				270	270							
				300	300							
		350	350									
		400	400									



Contact us:

www.wmvalvesuk.com
sales@wmvalvesuk.com

Warren-Morrison UK Ltd
Unit 1 Tower Lane Industrial Estate,
Tower Lane,
Eastleigh
SO50 6NZ
United Kingdom

Telephone : +44 (0) 2380 610734
Company Registration No : 03629310