

ClearFlo™ Sequencing Batch Reactor

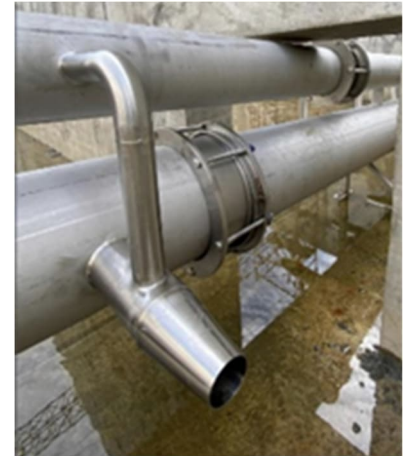

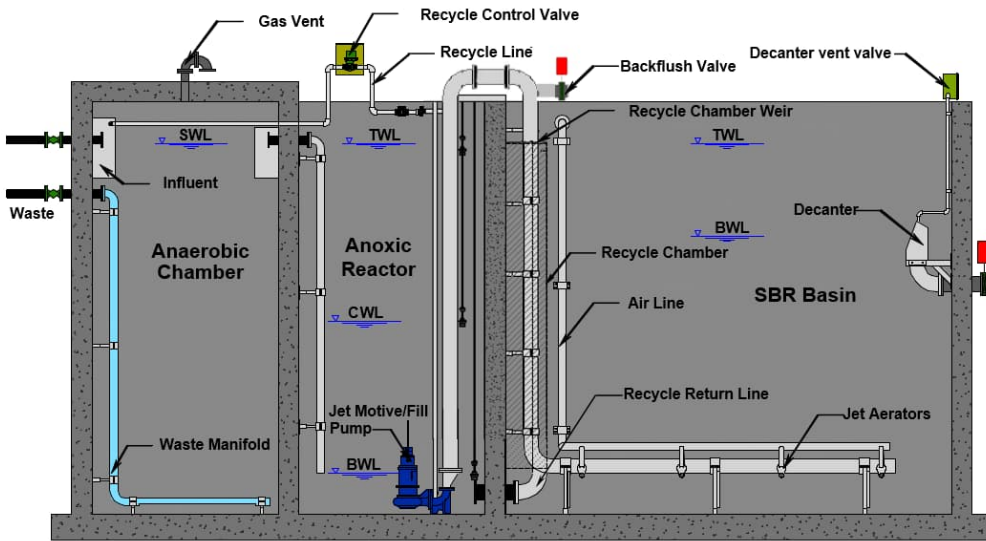

ClearFlo™ Jet Aerators

ClearFlo™ Biological Nutrient Reduction (BNR) Sequencing Batch Reactor with Anaerobic Selector and Sludge Reduction.

This is an alteration of the Modified Ludzack-Ettinger (MLE) Activated Sludge Process.

The MLE biological system comprises an anoxic reactor followed by an aerobic tank with internal recycle stream. In the aeration tank of MLE process, nitrification and ammonium nitrogen transformation to nitrate are performed consuming oxygen and some alkalinity.

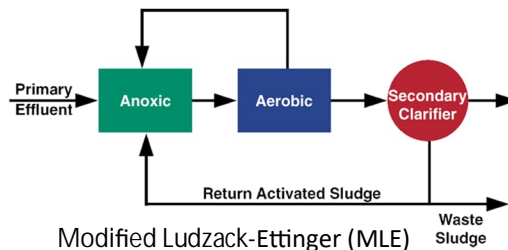

Modified Ludzack-Ettinger (MLE)

ClearFlo™ SBR Performs:

- Equalization
- Aeration
- WAS Recirculation
- Carbonaceous Removal
- Nitrification
- Denitrification
- Digestion
- Clarification

All in a single basin, multiple basins are combined to produce a continuous treatment flow.

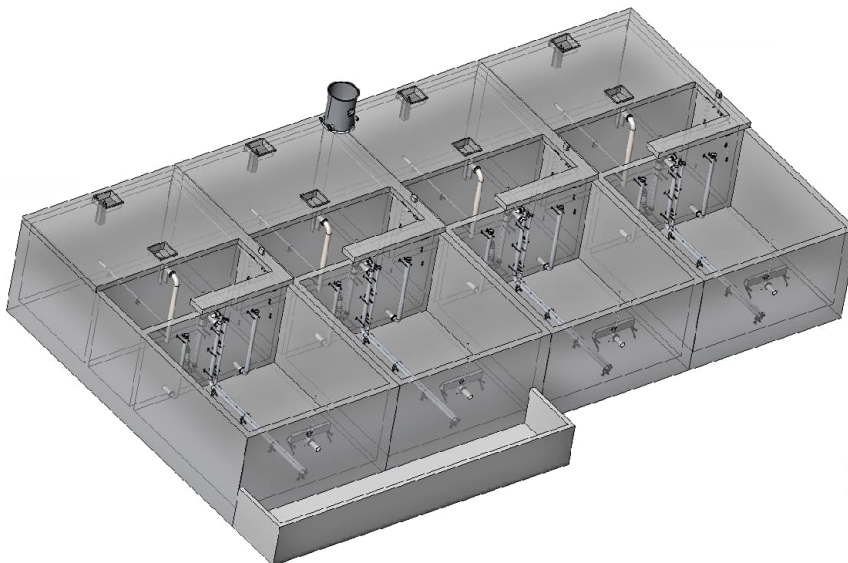

ClearStream produces a 3D model of every unit which we manufacture.

Desired Feature	ClearFlo Jets	Fine Bubble Diffusers	Coarse Bubble Diffusers	Surface Aerators	Brush Rotors
Independent Control of O ₂ Transfer and Mixing	Yes	No	No	No	No
Anoxic Mixing	Yes	No	No	No	No
No In-Basin Mechanical Components	Yes	Yes	Yes	No	No
No Mist, Spray, or Splash	Yes	Yes	Yes	No	No
Thermal Conservation	Yes	Yes	Yes	No	No
Low Maintenance	Yes	Yes	Yes	No	No
High Clean Water O ₂ Transfer Efficiency	Yes	Yes	No	No	No
High Alpha Value	Yes	No	Yes	Yes	Yes
Long Life	Yes	No	Yes	Yes	Yes
Adaptable to Any Basin Configuration	Yes	Yes	Yes	Yes	No
Adaptable to Continuous Loop Reactors	Yes	No	No	Yes	Yes



All Basin Internals are stainless steel

Features

- Separate Mixing from Aeration
- Fixed Position Decanter
- Self-Cleaning Nozzles
- No Elastomers or Membranes
- No Plastics to Break or Breakdown
- Extreme Control Flexibility
- High Turndown – Both Mixing and Aeration
- Combines Multiple Processes in Single Unit (Anoxic, Aerobic, Clarification)
- Fewer Pumps, Controls, etc.

Benefits

Independent Control of Oxygen Transfer and Mixing
 Air flow to each jet aerator can be varied from 10 SCFM to 80 SCFM to control oxygen delivery, without affecting mixing; jet systems can be operated ungasged for anoxic mixing. Anoxic mixing improves nutrient removal and settling.

No Mist, Spray, or Splash
 Walkways and handrails stay clean. Odors and airborne VOCs are reduced or eliminated.

Thermal Conservation
 Submerged release of warm compressed air, and lack of splashing eliminates freezing problems, even in the coldest climates; allowing year-round nitrification / denitrification.

ClearFlo™ Solids Excluding Decanter



ClearFlo™ Jet Aerators

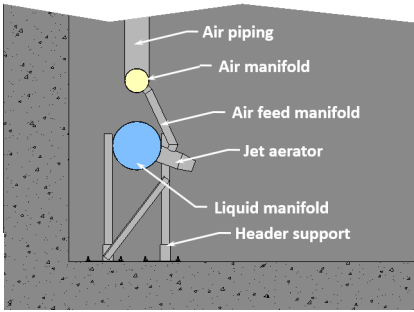

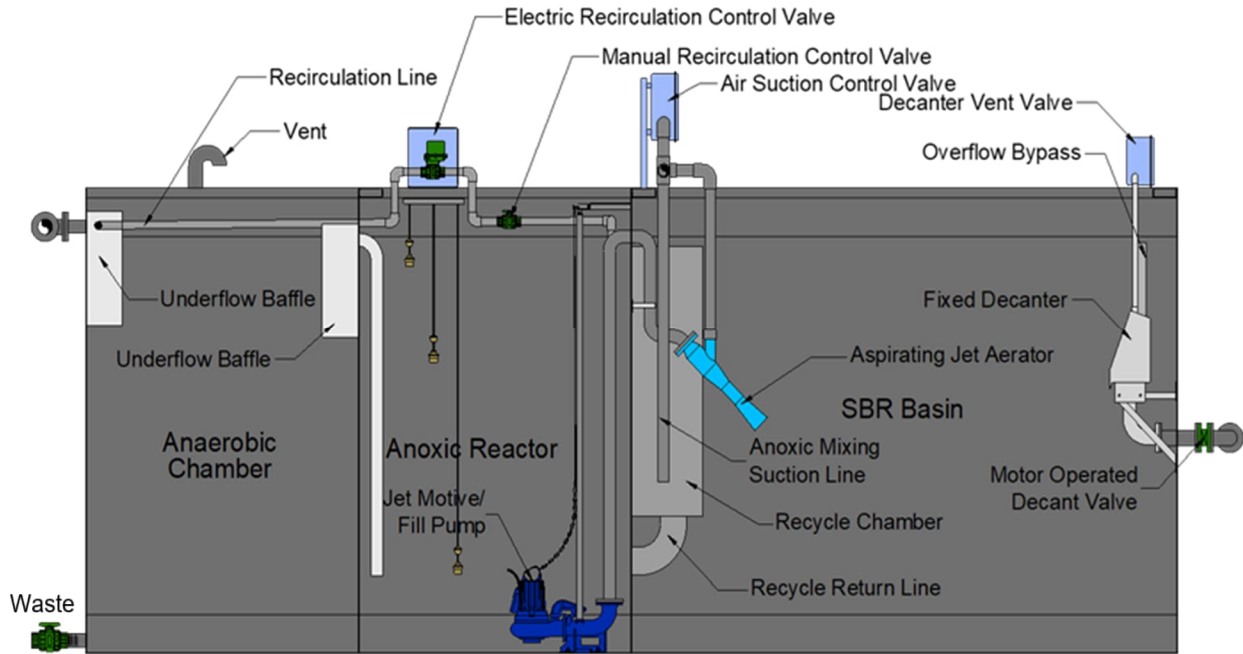

ClearFlo™ SBR systems are optimized for wide variety of applications; from small packaged single train systems, to large Constant Level SBR systems. State of the art SBR designs are available to meet the Nation's toughest BNR standards. Our proprietary operating strategy enables ClearFlo™ SBR systems to treat flows from zero to 350% of design flow without bypassing, or permit violations.

Normal Fill Phase: Influent enters the anaerobic chamber where 65% of solids settle. Flow to anoxic chamber is continuous.

Mixing Phase: When the level in the anoxic chamber reaches the control water level, the fill/mixing/WAS pump is started. The SBR basin is filled and mixed.

Decant Phase: Sludge is wasted to anaerobic chamber. Solids in anaerobic chamber are digested.



Pre-assembled Units

